

MDC151-050101 Series 50V, 10A Brushless DC Controller

User's Guide



ANAHEIM AUTOMATION

4985 E. Landon Drive Anaheim, CA 92807
e-mail: info@anaheimautomation.com

(714) 992-6990 fax: (714) 992-0471
website: www.anaheimautomation.com

MDC151-050101 Driver Features

- Maximum Current Limit Setting from 1.0-10.0 Amps (peak)
- Internal or External Potentiometer Speed Control
- 0V to 5V External Voltage Speed Control
- 2-Quadrant Operation
- Hall Sensor Feedback
- Constant Velocity Mode
- Short Circuit Protection
- Requires 20 - 50VDC
- Brake, Enable and Direction
- TTL-CMOS Compatible Inputs
- Dual Mounting Option
- Detachable, Screw Type Terminal Blocks

General Description

The MDC151-050101 driver is designed to drive DC brushless motors at currents of up to 10A (peak) and 50V. Using hall sensor feedback, a constant velocity mode can be selected. The driver is protected against over current (cycle-by-cycle or latched), hall sensor error and under voltage. When an error occurs, a fault light is turned on to notify the user. Included on the driver is an internal potentiometer to control the maximum phase current allowed into the motor and an internal potentiometer to control the speed of the motor. An external potentiometer (10K) can be used to control the speed as well. The direction of the motor can be preset by the direction control input. Other inputs to the drive include a dynamic brake and a motor disable input. When using the brake input, it overrides all other inputs into the driver.

Fault Protection

This driver is equipped with a FAULT LED to alert the user of the following conditions:

1. Invalid Sensor Input Code
2. Enable Input at Logic 0
3. Over Current. The driver is equipped with cycle-by-cycle current limiting or over current latch.
4. Undervoltage Lockout activation at 9.1VDC for the input voltage and 4.5VDC for the Hall Sensor voltage.

Ordering Information

Part #	Description
MDC151-050101	Featured BLDC driver 10A, 50V
PSA24V2.7A	DC Power Supply 24VDC at 2.7 Amps
PSA40V4A	DC Power Supply 40VDC at 4 Amps
PSA40V8A	DC Power Supply 40VDC at 8 Amps

Specifications

Control Inputs: (TB2, Pins 3-5)

TTL-CMOS Compatible

Logic "0" = 0-0.8VDC

Logic "1" = OPEN

All three inputs (brake, enable and direction) are pulled up through 20k Ohm resistors.

Enable: (TB2, Pin 5)

Logic "1" (open) - Motor is Enabled

Logic "0" - Motor is de-energized and will coast

Direction: (TB2, Pin 4)

Logic "1" (open) - Clockwise

Logic "0" - Counterclockwise

Brake: (TB2, Pin 3)

Logic "1" (open) - Motor will not run and if running will decelerate rapidly

Logic "0" - Motor will run

Output Current Rating:

Adjustable 1.0 - 10.0 amperes per phase maximum operating peak current

(0.5 - 5.0 amperes per phase maximum operating continuous current)

Power Requirements: (TB2, Pins 1 and 2)

20VDC (min) - 50VDC (max)

Operating Temperature:

Heat Sink: 0°-70° C

Hall Sensor Power Output:

6.25V @30mA maximum. Typical current draw from hall sensors in 20mA.

All three Hall Sensor inputs are pulled up through 150 ohm resistors.

The external speed control potentiometer must be 10K Ohms.

Heating Considerations

The temperature of the heat sink should never be allowed to rise above 70°C. If necessary, mount the unit to an additional heat sink or air should be blown across the heat sink to maintain suitable temperatures.

Open Loop/Closed Loop (Constant Velocity Mode)

The driver can either be set for Open Loop or Closed Loop operation. Open Loop operation is used for applications where the speed of the motor needs to change according to the load. In Open Loop operation, typically the greater the load, the speed of the motor decrease. Closed Loop operation is used for applications where speed regulation is needed. Under closed loop operation, the speed is regulated despite changes to the load and the power supply voltage.

To operate Open Loop, the O/C Loop jumper (JP4) needs to be on pins 1 and 2.

To operate Closed Loop, the O/C Loop jumper (JP4) needs to be off and the CL ADJ POT (R41) and CL ADJ Jumper (JP3) must be set to optimize the driver for each application. The Closed Loop adjustments are needed for faster and slower motor operation, within the restrictions of the motor rated speed. The adjustments provide a direct duty cycle to the driver with respect to the required motor speed.

The Tables shown on the next page are the Closed Loop potentiometer and jumper settings for each motor. These settings are valid for the listed motor rated voltage. These adjustments will set the maximum running speed of the internal/external speed potentiometer or the 5VDC voltage set to the motors maximum running speed. Motor operation at slower speeds may also be attained. For a slower speed, the pulse width of the duty cycle can be increased by adjusting the CL POT towards 100%.

If using a non-Anaheim Automation Motor:

1. Start by placing the jumper at JP4 is OFF for the Closed Loop setting
2. Place a jumper at JP3 on pins 1 and 2.
3. Set the internal speed pot or 10K external speed pot to 100%. The motor should be running at its maximum speed.
4. Set the CL ADJ POT to 50%.
5. If the maximum speed is too fast, slowly rotate CL ADJ POT towards 100% until the desired speed has been met. (The motor speed should be decreasing.)
6. If the maximum speed is too slow, slowly rotate CL ADJ POT towards 0% until the desired speed has been met. (The motor speed should be increasing.)
7. If the motor is not properly changing in speed, stalling, or cogging, switch the jumper at JP3 to pins 2 and 3 and go through steps 3-6 once again.

Anaheim Automation Motor Closed Loop Settings

4-Pole Motors

Motor	JP3	CL POT	SPD POT	MAX SPD (RPM)	MIN SPD (RPM)
BLWR111S-24V-10000	1-2	50%	100%	10000	350
BLWR112S-24V-3700	1-2	90%	70%	3700	165
BLWR231D-36V-4000	2-3	15%	100%	4000	290
BLWR232D-36V-4000	2-3	15%	100%	4000	360
BLWR233D-36V-4000	2-3	15%	100%	4000	300
BLWR234D-36V-4000	2-3	15%	100%	4000	300
BLWS231S-24V-2000	2-3	30%	100%	2000	360
BLWS232S-24V-1350	2-3	35%	100%	1350	405
BLWS231D-36V-4000 BLWS231S-36V-4000	2-3	15%	100%	4000	280
BLWS232D-36V-4000 BLWS232S-36V-4000	2-3	15%	100%	4000	270
BLWS232D-24V-1350	2-3	35%	100%	1350	405
BLWS233D-24V-4000	1-2	100%	85%	4000	250
BLWS233S-36V-4000	2-3	15%	100%	4000	370
BLWS234S-45V-1400	2-3	35%	100%	1400	420
BLWS234D-36V-4000 BLWS234S-36V-4000	2-3	15%	100%	4000	330
BLWS235S-24V-4000	2-3	15%	100%	4000	390
BLWS235-36V-4000	1-2	100%	80%	4000	340
BLWS235D-36V-10000	1-2	50%	100%	10000	600
BLWS242S-24V-2300	2-3	25%	95%	2300	240

8-Pole Motors

Motor	JP3	CL POT	SPD POT	MAX SPD (RPM)	MIN SPD (RPM)
BLWR172S-24V-2000	2-3	15%	100%	2000	130
BLWR172S-24V-4200	1-2	60%	100%	4200	160
BLWR173S-24V-2000	1-2	100%	80%	2000	135
BLY171D-24V-1400	2-3	20%	90%	1400	135
BLY171S-24V-4000	1-2	65%	100%	4000	170
BLY171D-24V-6000	1-2	40%	100%	6000	240
BLY172S-24V-2000	1-2	100%	80%	2000	115
BLY172D-24V-4000 BLY172S-24V-4000	1-2	65%	100%	4000	180
BLY173D-24V-4000	1-2	70%	100%	4000	190
BLY174D-24V-4000 BLY174S-24V-4000	1-2	60%	95%	4000	170
BLY174D-24V-12000	1-2	20%	90%	12000	360
BLK241S-36V-3000	1-2	90%	100%	3000	190
BLK242S-36V-3000	1-2	85%	100%	3000	190
BLY341D-24V-3000 BLY341S-24V-3000	1-2	80%	100%	3000	130
BLY342D-48V-3200	1-2	75%	100%	3200	160

Commutation Sequence

	Step					
	1	2	3	4	5	6
Phase A	+	Z	-	-	Z	+
Phase B	Z	+	+	Z	-	-
Phase C	-	-	Z	+	+	Z
Hall A	1	1	0	0	0	1
Hall B	0	1	1	1	0	0
Hall C	0	0	0	1	1	1

120° Hall Spacing Sequence Forward

	Step					
	1	2	3	4	5	6
Phase A	-	Z	+	+	Z	-
Phase B	Z	-	-	Z	+	+
Phase C	+	+	Z	-	-	Z
Hall A	1	1	0	0	0	1
Hall B	0	1	1	1	0	0
Hall C	0	0	0	1	1	1

120° Hall Spacing Sequence Reverse

	Step					
	1	2	3	4	5	6
Phase A	+	Z	-	-	Z	+
Phase B	Z	+	+	Z	-	-
Phase C	-	-	Z	+	+	Z
Hall A	1	1	1	0	0	0
Hall B	0	1	1	1	0	0
Hall C	0	0	1	1	1	0

60° Hall Spacing Sequence Forward

	Step					
	1	2	3	4	5	6
Phase A	-	Z	+	+	Z	-
Phase B	Z	-	-	Z	+	+
Phase C	+	+	Z	-	-	Z
Hall A	1	1	1	0	0	0
Hall B	0	1	1	1	0	0
Hall C	0	0	1	1	1	0

60° Hall Spacing Sequence Reverse

+ = Top Transistor ON, Bottom Transistor OFF, Current Flows into this wire

- = Top Transistor OFF, Bottom Transistor ON, Current Flows out of this wire

Z = Top Transistor OFF, Bottom Transistor OFF, No current into or out of this wire (High Impedance)

Motor Connection

Refer to the hookup diagram for typical driver applications. When connecting a motor for the first time, connect the hall sensor wires (5 of them) to the driver. **DO NOT CONNECT THE PHASES YET.** Turn on power and rotate the motor by hand. If the RED FAULT LED comes on, the hall phases are incorrectly wired. If the RED FAULT LED does not come on then the hall wires are connected correctly. Power the unit down and proceed to connect the motor phases. If the motor does not run or runs erratically, power down and check the speed potentiometer and make sure the phases are connected correctly. There are six different ways to connect the phase wires, and normally only two will allow the motor to rotate, but only one is correct. If the direction of the motor is changed and the no-load current of the motor is approximately the same and the motor runs smoothly in both directions then the phase wires are correct.

The wiring of the motor phases should be separated from the hall and input connections to not allow a possible source of interference.

Terminal and Dip Switch Descriptions

Pin #	Description
1	Phase A
2	Phase B
3	Phase C
4	Hall Sensor Power
5	Hall Sensor A
6	Hall Sensor B
7	Hall Sensor C
8	Hall Sensor Ground

TB1: Motor Terminals

Pin #	Description
1	VIN (20-50VDC)
2	GND/Pot GND
3	Brake
4	Direction
5	Enable
6	Pot Wiper
7	Pot Power

TB2: Input Terminals

Jumper Functions

Function	JP1	JP2	JP3	JP4
Constant Speed Mode (Closed Loop)	---	---	---	Open
Voltage Controlled Speed Mode (Open Loop)	---	---	---	1-2
60° Hall Sensor Spacing	Open	---	---	---
120° Hall Sensor Spacing	1-2	---	---	---
Internal Speed Control (R13)	---	1-2	---	---
External Speed Control (TB2 pins 2, 6 & 7)	---	2-3	---	---
Standard Product (Ready to Ship)	1-2	1-2	1-2	1-2

Motor Enable

The motor enable feature allows the de-energizing of the motor phases. An open input at this input causes the motor to run at the given speed, while a low at this input causes the motor to coast to a stop.

Motor Brake

The motor brake feature allows the stopping of a motor by shorting out the bottom drives of the three phases. A low at this input allows the motor to run, while an open input does not allow motor operation and if operating causes rapid deceleration.

Motor Direction

The motor direction feature allows the changing of the rotation of the motor. This input should not be changed while motion is in progress. An open input causes the motor to turn in the CW direction, while a low at this input causes the motor to turn the CCW direction.

Note: Avoid changing the direction of rotation when the motor is already running in any one direction.

The following instructions must be followed to prevent permanent driver failure due to over-current conditions that exist in dynamic direction reversals of the motor:

1. Stop the motor by removing the ground signal on the BRAKE input.
2. Wait for at least 500mS
3. Change the direction with the DIRECTION input.
4. Run the motor by grounding the BRAKE input.

Speed Adjust Setting

There are two ways to set the speed on this drive. One is to use the on board potentiometer. The other is to use an external 10K potentiometer. To use the on board potentiometer, set jumper JP2 to position 1-2 (default). To use the external 10K potentiometer, set jumper JP2 to position 2-3.

Jumper/Potentiometer Locations

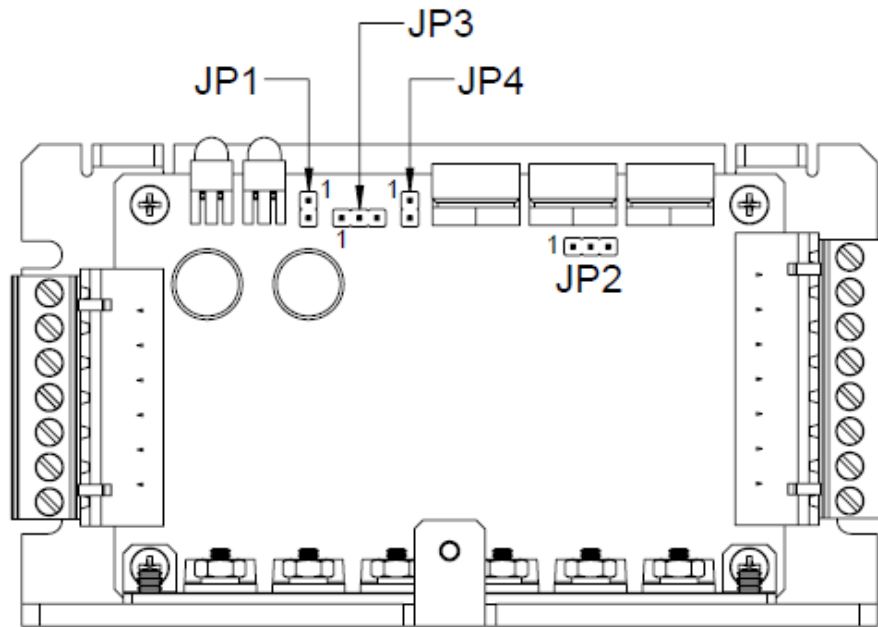

Typical Wiring Diagram

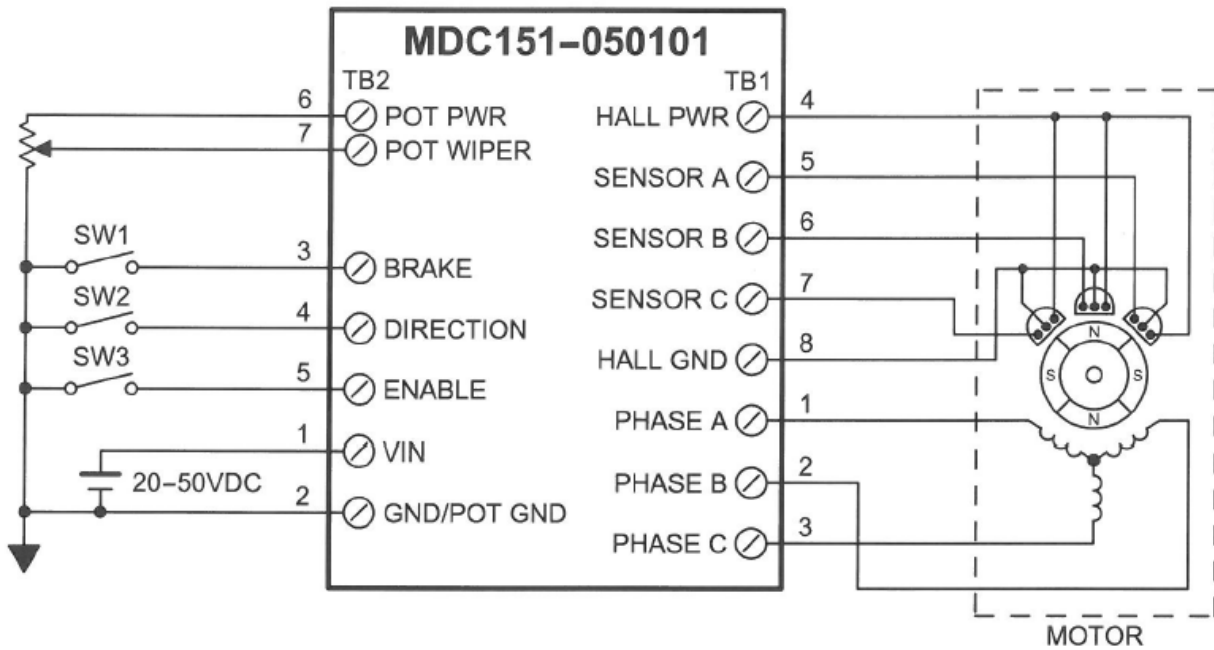

Dimensions

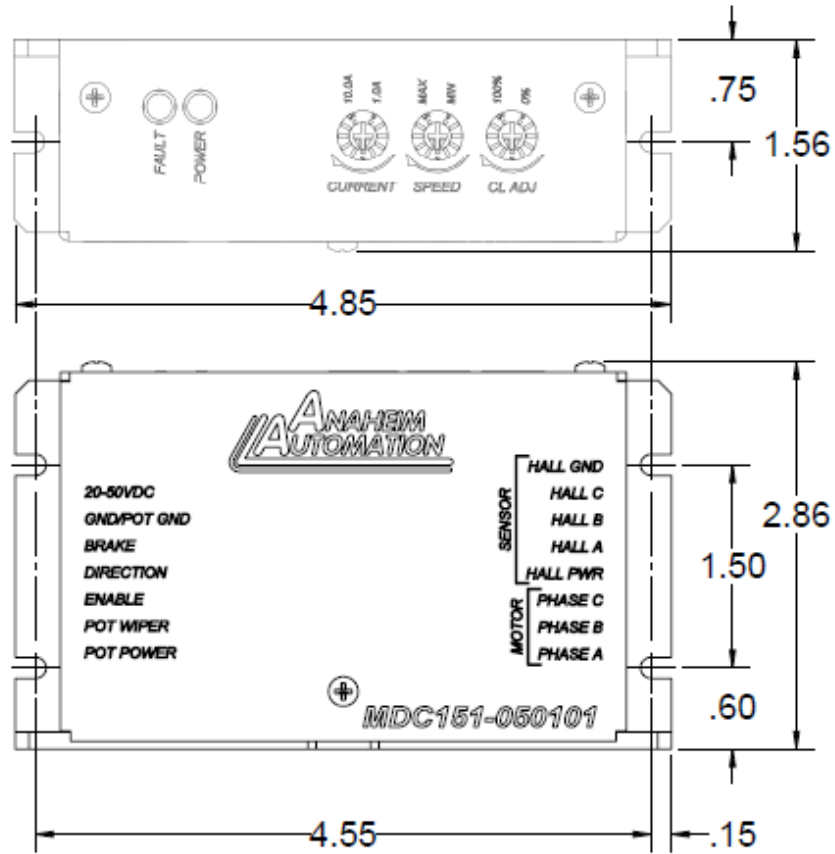

Torque Curves

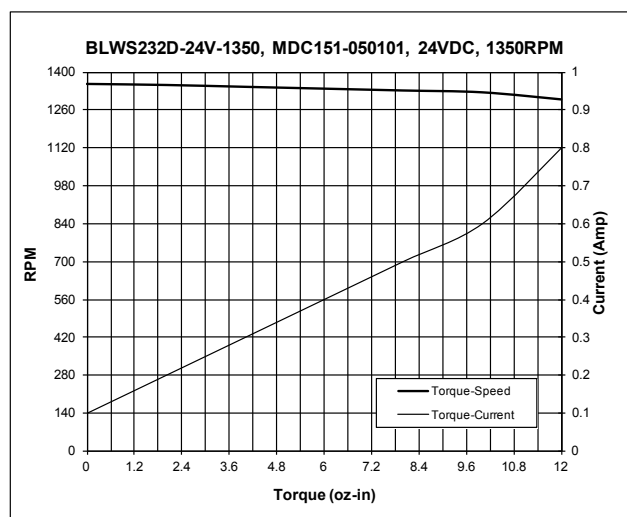
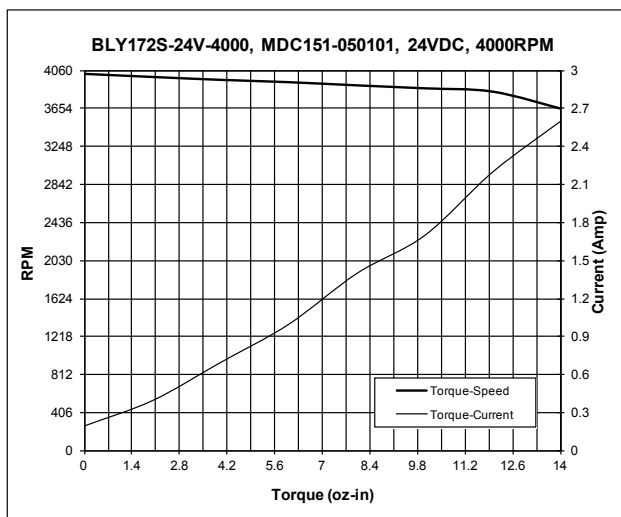

COPYRIGHT

Copyright 2014 by Anaheim Automation. All rights reserved. No part of this publication may be reproduced, transmitted, transcribed, stored in a retrieval system, or translated into any language, in any form or by any means, electronic, mechanical, magnetic, optical, chemical, manual, or otherwise, without the prior written permission of Anaheim Automation, 4985 E Landon Drive, Anaheim, CA 92807.

DISCLAIMER

Though every effort has been made to supply complete and accurate information in this manual, the contents are subject to change without notice or obligation to inform the buyer. **In no event will Anaheim Automation be liable for direct, indirect, special, incidental, or consequential damages arising out of the use or inability to use the product or documentation.**

Anaheim Automation's general policy does not recommend the use of its' products in life support applications wherein a failure or malfunction of the product may directly threaten life or injury. Per Anaheim Automation's Terms and Conditions, the user of Anaheim Automation products in life support applications assumes all risks of such use and indemnifies Anaheim Automation against all damages.

LIMITED WARRANTY

All Anaheim Automation products are warranted against defects in workmanship, materials and construction, when used under Normal Operating Conditions and when used in accordance with specifications. This warranty shall be in effect for a period of twelve months from the date of purchase or eighteen months from the date of manufacture, whichever comes first. **Warranty provisions may be voided if products are subjected to physical modifications, damage, abuse, or misuse.**

Anaheim Automation will repair or replace at its' option, any product which has been found to be defective and is within the warranty period, provided that the item is shipped freight prepaid, with previous authorization (RMA#) to Anaheim Automation's plant in Anaheim, California.

TECHNICAL SUPPORT

If you should require technical support or if you have problems using any of the equipment covered by this manual, please read the manual completely to see if it will answer the questions you have. If you need assistance beyond what this manual can provide, contact your Local Distributor where you purchased the unit, or contact the factory direct.

ANAHEIM AUTOMATION